



DESCRIPTIONS

The BMWS-L-D-5BT-BLE-KL is a battery powered wall switch with a long battery life of over 3 years. The switch can be wall mounted in a standard switch device box or used as a remote control.

FEATURES

- Bluetooth network technology enables the switch to link to one or more BlueMesh Light Groups via BlueMesh App.
- Powered by readily available and inexpensive 3V CR2032 battery.
- 3 scenes rotation controlled by scene button.
- Push Auto button to go back to Automatic mode.
- When the battery power is low, pressing any button will cause the LED indicator to flash red.
- Easily retrofit existing wall switches by WP kits.
- No wiring required.

TECHNICAL DATA

Input Voltage: DC 3V
 Bluetooth Transmit: 100ft Max
 Radio Frequency: 2.4GHz ± 75MHz
 Bluetooth Version: 4.2
 Housing Material: UL 94-V0
 Indoor Use Only
 Operating Temperature: -18°C to 50°C,
 -0.4°F to 122°F
 Storage Temperature: 0°C to 30°C,
 32°F to 86°F
 IP Rating: IP20
 Warranty: 5 years warranty

Comply to UL1376, RoHS

PHYSICAL DIMENSIONS

Unit: inch/mm

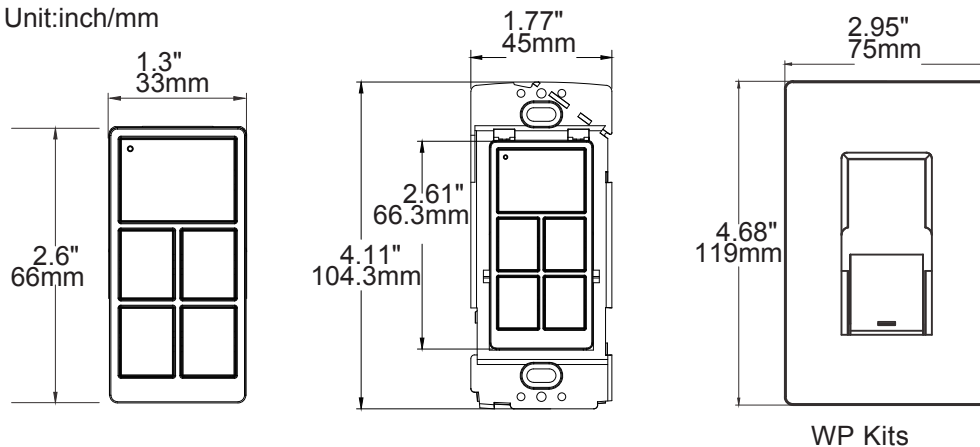

ORDERING INFORMATION

Model No.	Description
BMWS-L-D-5BT-BLE-KL-WH	Bluetooth Wireless Battery Powered Wall Switch with 5 Buttons, white
BMWS-WPK-WH	Wall Plate Kits, white
<p>Revise -WH suffix for different color options:</p> <ul style="list-style-type: none"> -WH - White (standard) -IV - Ivory -LA - Light Almond -GY - Gray -BK - Black -RD - Red <p>* White color is standard. Optional and Custom colors may require an additional charge.</p>	

WARRANTY

Five year limited warranty.

Specifications subject to change without notice.